



2126 W. 21st. St. • P.O. Box 12273 • Jacksonville, FL 32209
904-475-1822 • FAX 904-355-2104

DOUBLE WALL OVAL DUCT

Where double wall ductwork is required by specification, all double wall oval ductwork will be spiral lockseam or longitudinal seam construction with matching fittings. Construction of the outer shell will be in accordance with the following tables.

SMACNA 1985 GAUGES

MAJOR AXIS	SPIRAL GA.	LONG SEAM GA.	FITTING GA
TO 24"	24	20	20
25" - 36"	22	20	20
37" - 48"	22	18	18
49" - 60"	20	18	18
61" - 70"	20	16	16
71" +	18	16	16

Duct and fittings will be made from galvanized steel per ASTM- A 527. The zinc coating will be G-60 or higher.

Insulation will be one inch thick or higher if specified with K value of .27 or better.

Fittings will be constructed with solid liners of 24 gauge or heavier galvanized steel. Ductwork will be constructed with a perforated inner liner of galvanized steel ribbed spiral lockseam. Perforated material will have an open area of 23%.

Fitting seams will be tack welded and sealed with a high pressure duct sealant unless required to be fully welded by specification.

All elbows, both easy-bend and hard-bend, will have a center-line radius of 1.5 times the minor or major depending of required configuration. Elbows will be gored construction according to the following table.

DEGREES	GORES
0 -30	2
31 - 75	3
76 - 90	5

2126 W. 21st. St.

P.O. Box 12273

Jacksonville, FL 32209

(904) 475-1822

FAX (904) 355-2104

Job _____

Contractor _____

Location _____

Engineer _____

Representative _____

Date _____

DOUBLE WALL OVAL DUCT AND FITTINGS

<p>DOE90-5E ($A \leq 24"$)</p> <p>Fabricated Gore 90° Elbow Easy Bend</p>	<p>DOE90-5E ($A > 24"$)</p> <p>Fabricated 5 Gore 90° Elbow Easy Bend</p>	<p>DOE90-5H ($A \leq 24"$)</p> <p>Fabricated 5 Gore 90° Elbow Hard Bend</p>																																						
<p>DOE90-5H ($A \geq 24"$)</p> <p>Fabricated 5 Gore 90° Elbow Hard Bend</p>	<p>DOEH90-3E</p> <p>Fabricated 3 Gore Heel Tap 90° Elbow Easy Bend</p>	<p>DOEH90-3H</p> <p>Fabricated 3 Gore Heel Tap 90° Elbow Hard Bend</p>																																						
<p>DOEE90-2 OR DOEH90-2</p> <table border="1" style="margin-left: auto; margin-right: auto; border-collapse: collapse;"> <thead> <tr> <th colspan="2">Easy or Hard Bend</th> </tr> <tr> <th>A Inches</th> <th>Number of Vanes</th> </tr> </thead> <tbody> <tr> <td>3-9</td> <td>2</td> </tr> <tr> <td>10-12</td> <td>3</td> </tr> <tr> <td>14-18</td> <td>4</td> </tr> <tr> <td>20 and UP</td> <td>5</td> </tr> </tbody> </table> <p>Mitered 2-Piece 90° Elbow Easy Bend or Hard Bend (as shown)</p>	Easy or Hard Bend		A Inches	Number of Vanes	3-9	2	10-12	3	14-18	4	20 and UP	5	<p>DOTVE OR DOTVH</p> <table border="1" style="margin-left: auto; margin-right: auto; border-collapse: collapse;"> <thead> <tr> <th colspan="2">Easy Bend Elbow</th> </tr> <tr> <th>A Inches</th> <th>Number of Vanes</th> </tr> </thead> <tbody> <tr> <td>3-5</td> <td>1</td> </tr> <tr> <td>6-9</td> <td>2</td> </tr> <tr> <td>10-14</td> <td>3</td> </tr> <tr> <td>15-19</td> <td>4</td> </tr> <tr> <td>20 and UP</td> <td>5</td> </tr> </tbody> </table> <table border="1" style="margin-left: auto; margin-right: auto; border-collapse: collapse;"> <thead> <tr> <th colspan="2">Hard Bend Elbow</th> </tr> <tr> <th>A Inches</th> <th>Number of Vanes</th> </tr> </thead> <tbody> <tr> <td>7-9</td> <td>2</td> </tr> <tr> <td>10-14</td> <td>3</td> </tr> <tr> <td>15-19</td> <td>4</td> </tr> <tr> <td>20 and UP</td> <td>5</td> </tr> </tbody> </table> <p>Bull Head Tee Easy Bend or Hard Bend (as shown)</p>		Easy Bend Elbow		A Inches	Number of Vanes	3-5	1	6-9	2	10-14	3	15-19	4	20 and UP	5	Hard Bend Elbow		A Inches	Number of Vanes	7-9	2	10-14	3	15-19	4	20 and UP	5
Easy or Hard Bend																																								
A Inches	Number of Vanes																																							
3-9	2																																							
10-12	3																																							
14-18	4																																							
20 and UP	5																																							
Easy Bend Elbow																																								
A Inches	Number of Vanes																																							
3-5	1																																							
6-9	2																																							
10-14	3																																							
15-19	4																																							
20 and UP	5																																							
Hard Bend Elbow																																								
A Inches	Number of Vanes																																							
7-9	2																																							
10-14	3																																							
15-19	4																																							
20 and UP	5																																							

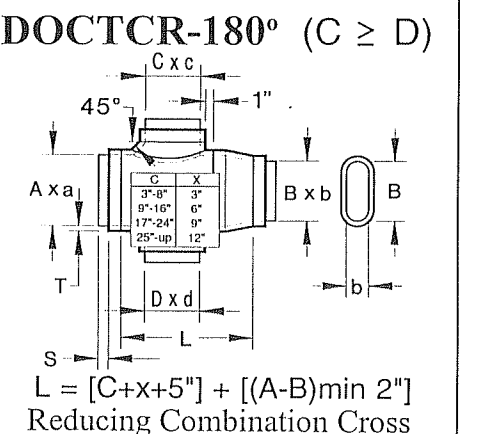
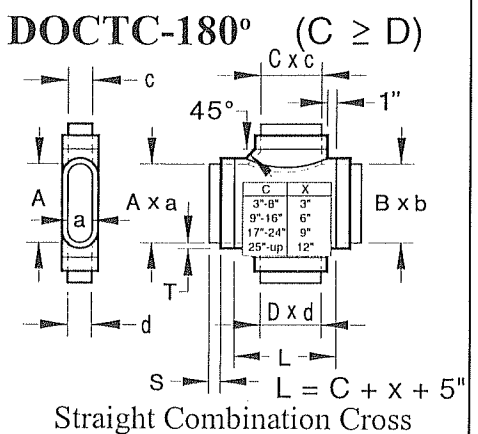
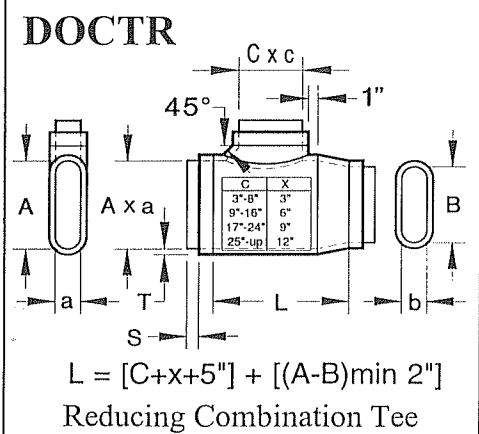
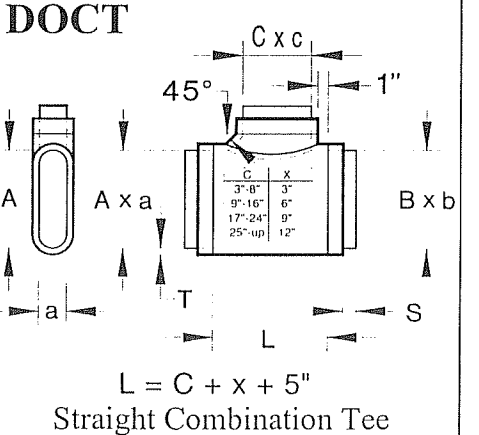
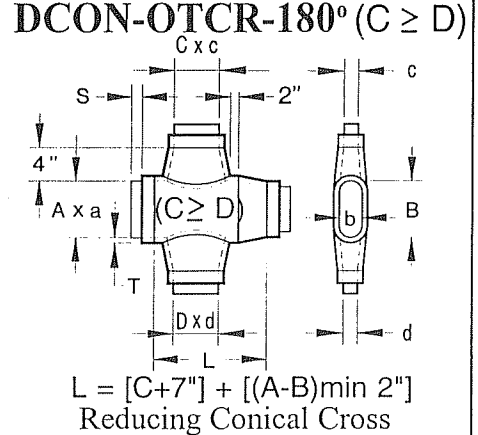
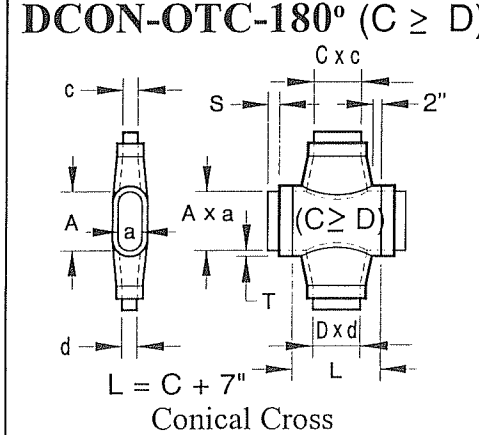
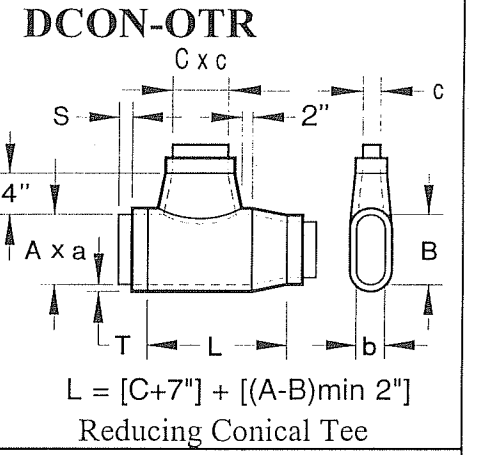
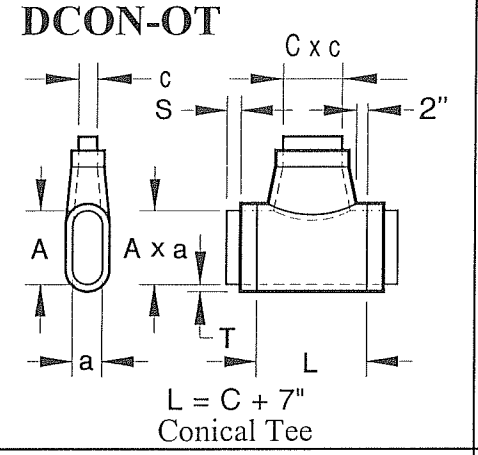
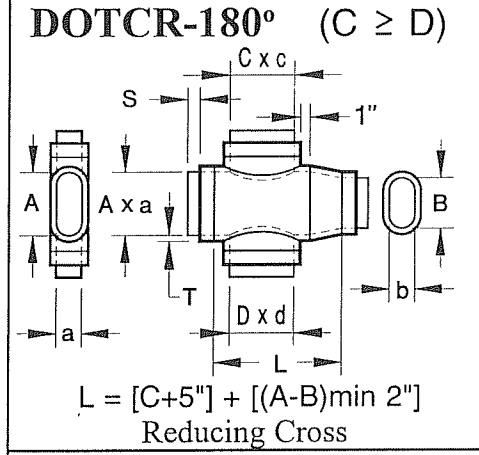
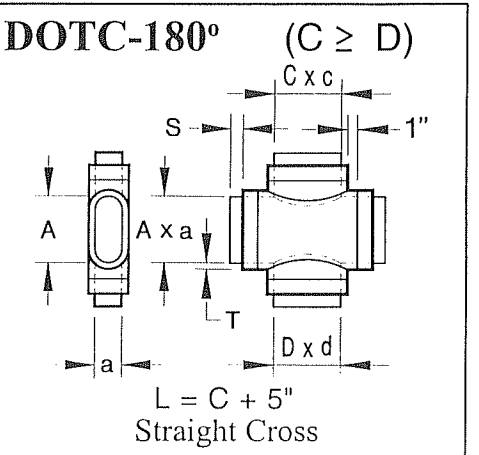
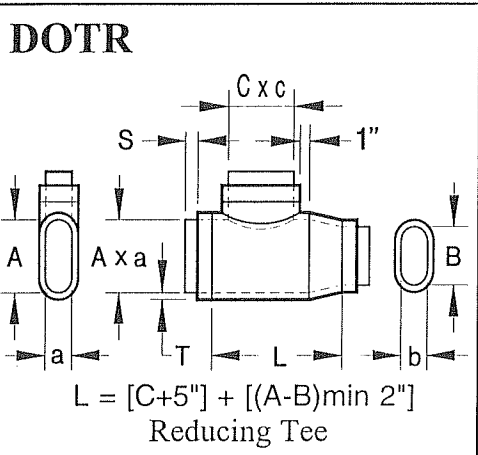
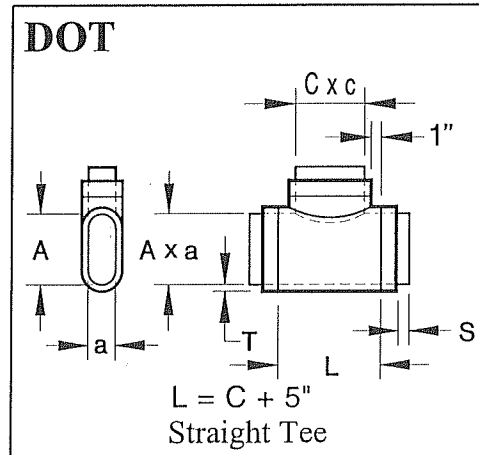

<p style="text-align: center;">DOYH-90</p> <p style="text-align: center;">A=B=C a=b=c</p> <p style="text-align: center;">Non-Reducing Wye Hard Bend</p>	<p style="text-align: center;">DOYRH-90</p> <p style="text-align: center;">Reducing Wye Hard Bend</p>	<p style="text-align: center;">DOL</p> <p style="text-align: center;">$L = 1.414C + 5''$</p> <p style="text-align: center;">Straight Lateral 45°</p>
<p style="text-align: center;">DOLR</p> <p style="text-align: center;">$L = [1.414C + 5''] + [(A-B)\text{min}2'']$</p> <p style="text-align: center;">Straight Reducing Lateral</p>	<p style="text-align: center;">DOL-180 (C ≥ D)</p> <p style="text-align: center;">$L = 1.414C + 5''$</p> <p style="text-align: center;">Lateral Cross</p>	<p style="text-align: center;">DOL-180 C ≥ D</p> <p style="text-align: center;">$L = [1.414C + 5''] + [(A-B)\text{min}2'']$</p> <p style="text-align: center;">Reducing Lateral Cross</p>
<p style="text-align: center;">DOSETE</p> <p style="text-align: center;">Z and L to be specified</p> <p style="text-align: center;">Offset Easy Bend</p>	<p style="text-align: center;">DOSETH</p> <p style="text-align: center;">Z and L to be specified</p> <p style="text-align: center;">Offset Hard Bend</p>	<p style="text-align: center;">DQO</p> <p style="text-align: center;">A, B, C and L to be specified</p> <p style="text-align: center;">1"</p> <p style="text-align: center;">Square to Oval Offset Transitions Available</p>
<p style="text-align: center;">DOR</p> <p style="text-align: center;">Eccentric Oval to Flat Oval Transitions can be supplied in a variety of configurations. Please consult the factory or supply a sketch of the fitting.</p>		

DOR

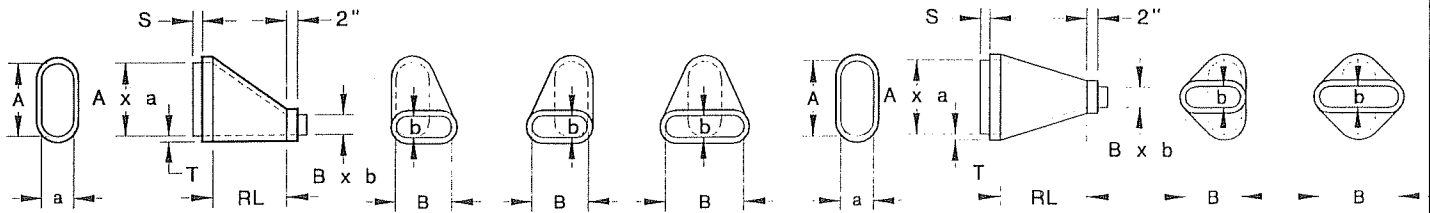

Rotated Axis to Flat Oval Eccentric Transitions can be supplied in a variety of configurations. Please consult the factory or supply a sketch of the fitting.

DOR

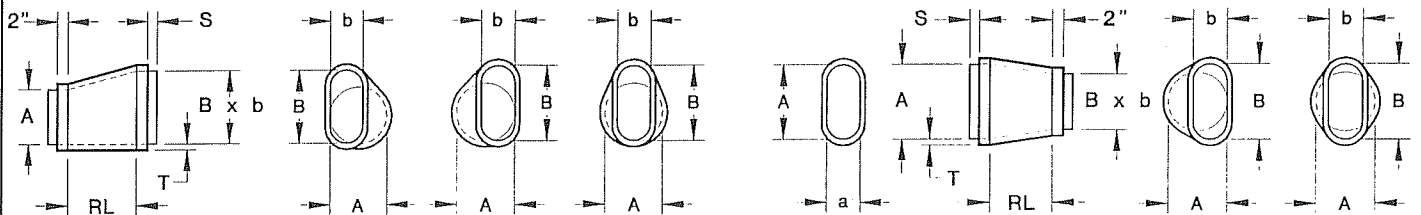

Eccentric Round to Flat Oval Eccentric Transitions can be supplied in a variety of configurations. Please consult the factory or supply a sketch of the fitting.

Specifications

Double wall oval duct and fittings are fabricated of galvanized steel meeting ASTM A-527 & A-525 standards. Spiral lock seam oval duct can be provided in any length or standard lengths of 6, 10, or 12 feet. Longitudinal seam oval duct can be supplied in lengths up to 5 feet. Duct has a construction tolerance of plus or minus 1/2 inch in length. Internal liner of duct, unless otherwise specified, is perforated (1/32" diameter holes on 3/16" staggered centers, yielding approx. 23% open area) and is solid for fittings. The liner shall be of ribbed construction when I.D. exceeds 14". Fitting seams are either welded seam, spot welded and bonded seam, or punch lock and bonded seam construction, depending on SMACNA's standards. Welded joints are coated with a corrosion resistant paint. Spot

welded fitting joints are sealed with a bonding cement. Tee and lateral tap entrances are fabricated with radiused entrances, free of weld build-up, burrs or irregularities. Standard centerline radius for elbows is 1 1/2 times the diameter unless otherwise noted. The radius on an elbow is bead to bead unless noted. Elbows are of mitered or gored construction. Fittings normally have 2" slip fit connections which slip inside the duct. Fittings have a construction tolerance of plus or minus 1/4 inch. Duct to duct as well as fitting to fitting couplings are available. Angle ring connections are available either welded to the spiral duct or Van Stoned to the fitting. Longitudinal seam duct 20 gauge and heavier are continuously welded, 22 gauge and lighter are spot welded and bonded.

Minimum Gauges for Double Wall Oval Duct and Fittings

0-10 Inch WG SMACNA Standard						0-2 Inch WG Impulse Air Standard				
Major Axis Inches	Outer Shell Duct	Outer Shell Longitudinal Seam	Outer Shell Fitting	Inner Liner Duct	Inner Liner Fittings	Major Axis Inches	Ribbed Spiral Duct	Outer Shell Fitting	Inner Liner Duct	Inner Liner Fittings
9-24	24	20	20	28	24	9-30	28	26	28	24
25-36	22	20	20	28	24	31-42	28	24	28	24
37-48	22	18	18	28	22	43-49	26	24	28	22
49-60	20	18	18	26	22	50-60	26	22	26	22
61-70	20	16	16	26	20	61-68	N/A	22	26	20
71-82	18	16	16	26	20	69-82	N/A	20	26	20

Dimensioning: A = dia. of inlet major axis a = dia. of inlet minor axis B = dia. of outlet major axis b = dia. of outlet minor axis C, D, E, F = dia. of tap inner liner major axis c,d,e,f = dia. of tap inner liner minor axis

R = centerline radius Z, X, L = misc. dimensions RL = reducer length.

RL = 12" for cases where A-B ≤ 15. Where A-B ≥ 16", RL to equal 24". All tees are 90° and laterals are 45° unless noted.

Impulse Air is continuously improving its product design and construction techniques. We reserve the right to alter and change specifications and dimensions at any time without prior notice.